



Douglas Wilson Companies

FOR SALE

3191 COMMERCIAL STREET, SAN DIEGO, CA 92113

\$2,950,000

DOUGLASWILSON.COM

OWNER/USER INDUSTRIAL BUILDING



BUILDING FACTS

- 13,100 SF Total
(4,900 SF Office)
- 18,000 SF Lot
- Fenced Yard & Parking
- 3 Grade Level Doors
- 800 Amps, 220/440
(3 phase power)
- Opportunity Zone
- Existing Tenant Lease
Expires February 28, 2020
- Sprint Antennae Lease
Provides Monthly Income
- Building Can Be Connected to
Contiguous 3167 Building By
Adjacent Roll Up Doors
- CN 1-4 Zoning

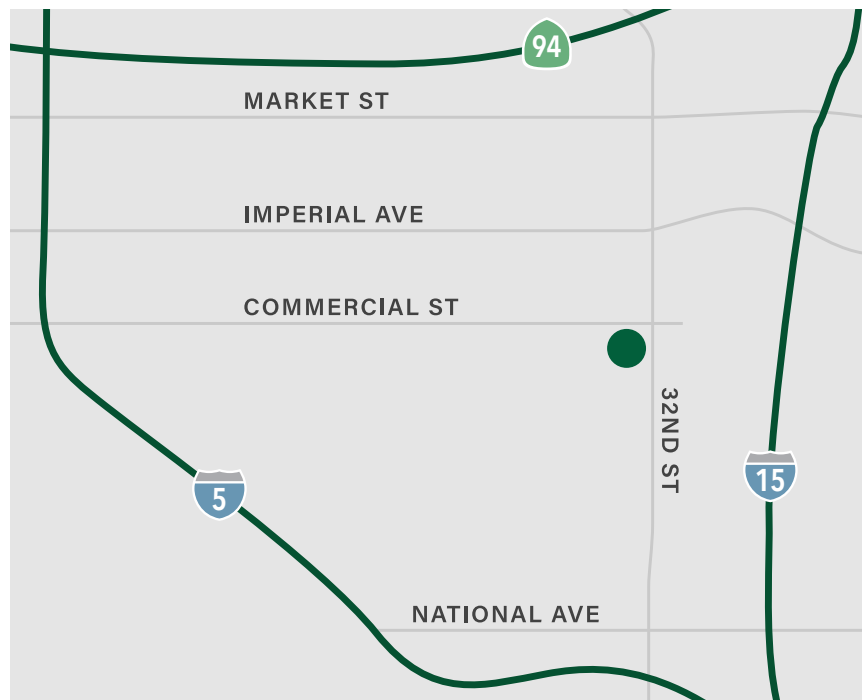

The information contained herein has been obtained from sources deemed reliable but cannot be guaranteed for its accuracy. We recommend to the buyer that all information be independently verified. ALL MEASUREMENTS CONTAINED HEREIN ARE APPROXIMATE.

FLOOR PLAN OF 3191 COMMERCIAL STREET

FIRST FLOOR

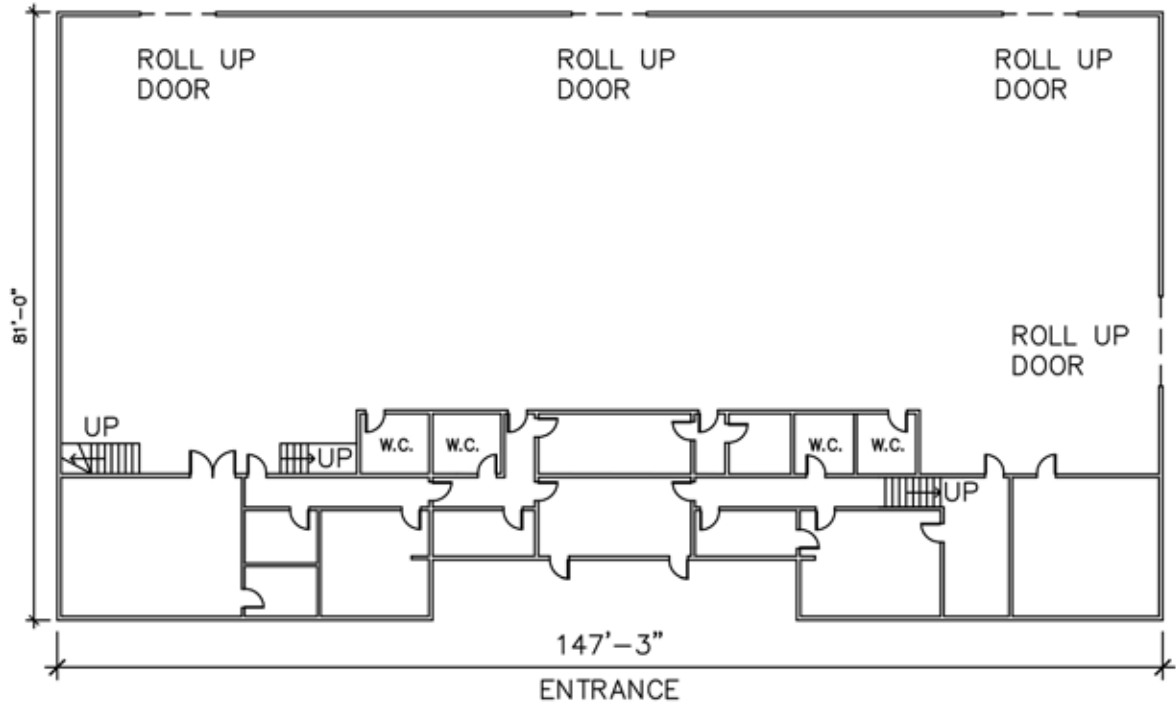

SECOND FLOOR

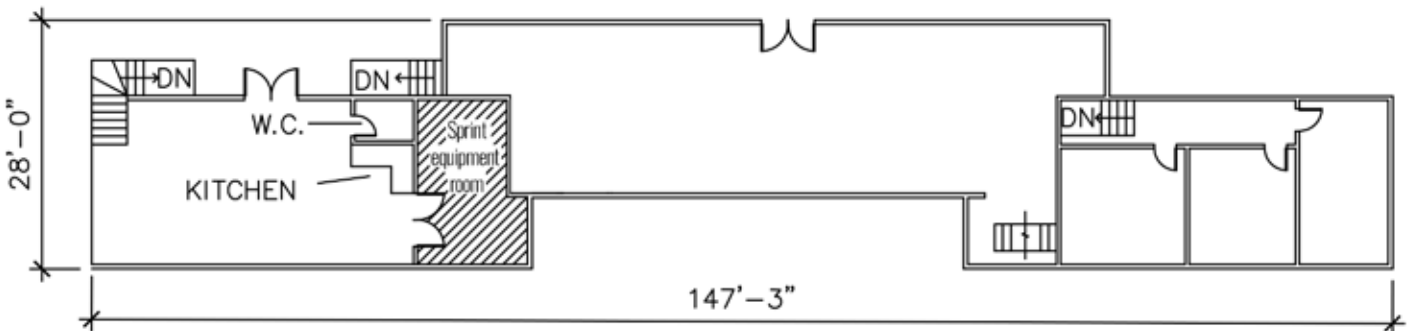

The information contained herein has been obtained from sources deemed reliable but cannot be guaranteed for its accuracy. We recommend to the buyer that all information be independently verified. ALL MEASUREMENTS CONTAINED HEREIN ARE APPROXIMATE.