



Douglas Wilson Companies

FOR SALE

105 SOUTH 31ST STREET, SAN DIEGO, CA 92113

\$2,300,000

DOUGLASWILSON.COM

OWNER/USER INDUSTRIAL BUILDING



BUILDING FACTS

- 15,960 SF Total (3,100 SF Office)
- 18,252 SF Lot
- Small Fenced Yard
- 7 Grade Level Doors
- 200 Amps (3 phase power)
- Opportunity Zone
- Existing Tenant Lease Expires October 31, 2020
- CN 1-4 Zoning

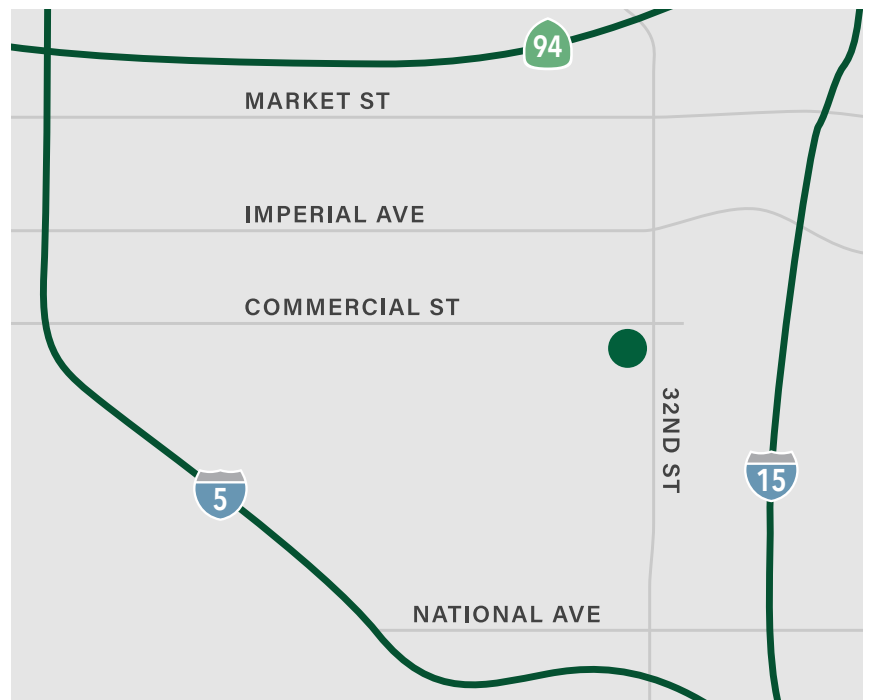

The information contained herein has been obtained from sources deemed reliable but cannot be guaranteed for its accuracy. We recommend to the buyer that all information be independently verified. ALL MEASUREMENTS CONTAINED HEREIN ARE APPROXIMATE.

FLOOR PLAN OF 105 SOUTH 31ST STREET

FIRST FLOOR

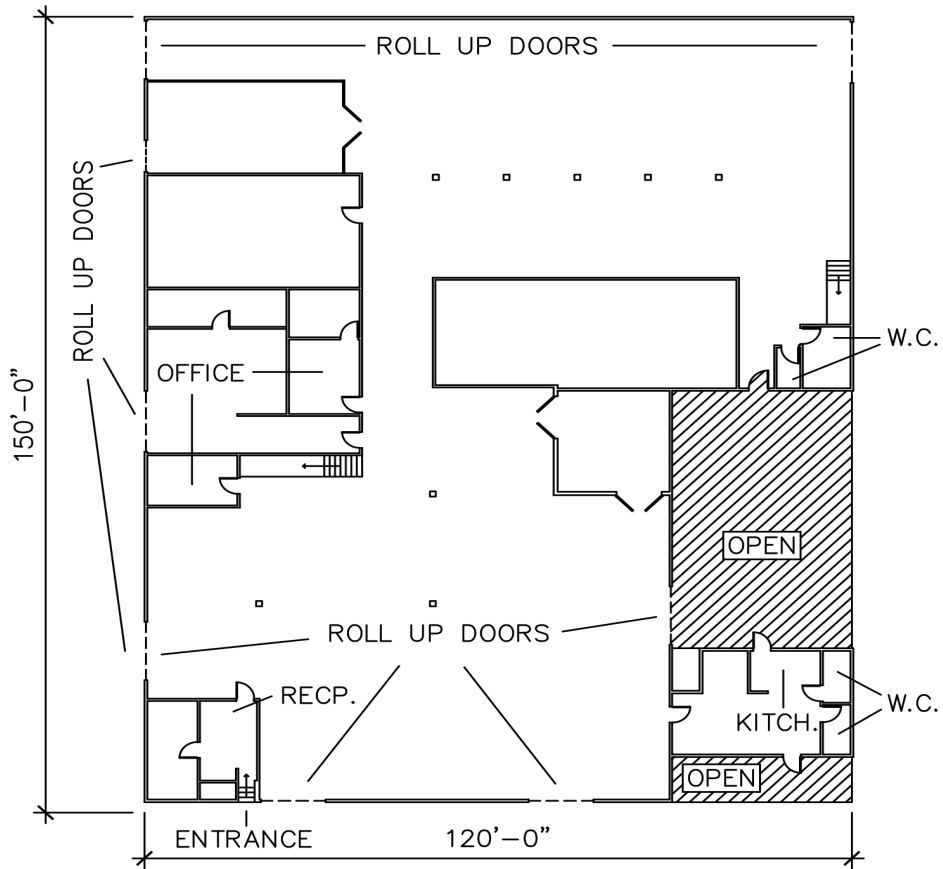

SECOND FLOOR

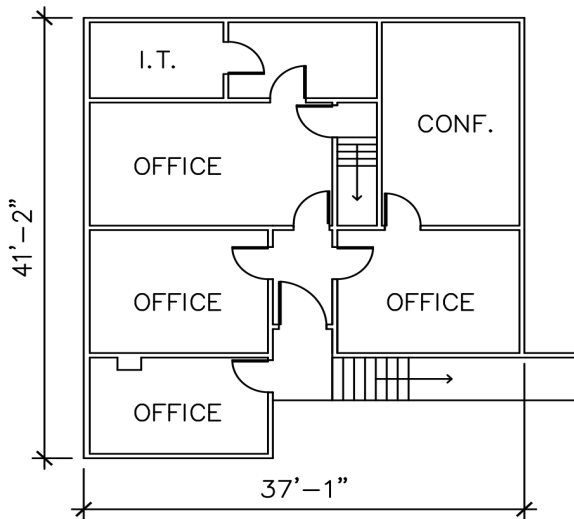

THIRD FLOOR

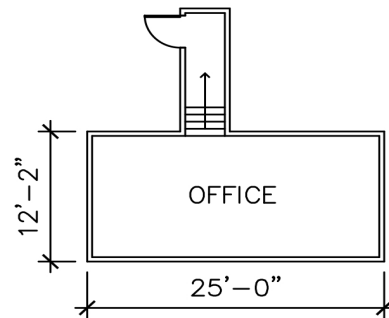

The information contained herein has been obtained from sources deemed reliable but cannot be guaranteed for its accuracy. We recommend to the buyer that all information be independently verified. ALL MEASUREMENTS CONTAINED HEREIN ARE APPROXIMATE.